



Powered by Menasha Corporation

PRODUCT SPEC SHEET

# 4048 ODYSSEY® HEAVY DUTY (HD) PALLET

The 40 x 48 Odyssey® Heavy Duty pallet is designed for efficient handling of heavy loads in a wide variety of unsupported racking applications.

The efficient storage and transportation of palletized product is key to designing an effective and economical supply chain.

The Odyssey rackable pallet is a robust solution that supports heavy loads and provides load stability with unique design features, including steel reinforcements and permanent molded-in frictional elements. This plastic pallet is an ideal alternative to wood, as it is fully reusable and offers dimensional consistency optimized for automated equipment.

- **Racking strength** – High strength-to-weight ratio capable of unsupported rack loads up to 2,800 lbs
- **Load stability** – Permanent, molded-in frictional elements minimize load shifting and do not damage product packaging
- **Ergonomic** – Lightweight design and comfortable hand holds for easy manual handling
- **Impact resistant** – Robust and highly resistant to impact from equipment, ideal for rugged applications
- **Hygienic** – Flow-through, hygienic design for easy cleanability

ORBIS' latest innovation builds on the success of decades of pallet innovation, from materials to design. **Contact an ORBIS representative today to reduce transportation costs and streamline your operations.**



### Odyssey Applications

- General food production (cold and frozen storage of meat, bakery, produce and dairy)
- Beverage manufacturing and distribution (carbonated soft drinks, juice, water)
- Dry goods (apparel, periodicals, pharmaceuticals) and consumer packaged goods
- Agriculture, including seed and farm materials
- Inbound receipt of raw materials and finished goods storage



Minimize load shifting with optional molded-in black frictional elements (shown in green for illustration)



Optional steel reinforcements offered in 40", 48" or both directions



Keep plants and equipment clean with hygienic design options

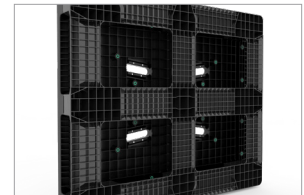

Seamless conveyance with full stringer bottom

(800) 890.7292

+1 (262) 560.5000

[www.orbiscorporation.com](http://www.orbiscorporation.com)

**A Better Way with ORBIS®**

The information contained herein is subject to change without notice. Statements regarding the application of the product(s) are based on general industry knowledge and are non-binding; it is the customer's responsibility to validate that a particular product is suitable for use in a particular application. The information contained herein does not expand or otherwise modify ORBIS' terms and conditions of sale, including, but not limited to, the warranty expressed therein. ORBIS hereby disclaims: (1) all liability with respect to the accuracy, reliability, or completeness of the information contained herein; and (2) all warranties, express or implied, with respect to the information contained herein, including, without limitation, with respect to the suitability of the products for any particular purpose or application. ©2025 ORBIS Corporation (05/25)

PRODUCT SPEC SHEET

# 4048 ODYSSEY® HD PALLET

ORBIS' latest innovation builds on the success of decades of pallet innovation, from materials to design – the 4048 Odyssey HD pallet is designed for efficient handling of heavy loads in a wide variety of unsupported racking applications.

## Pallet Dimensions

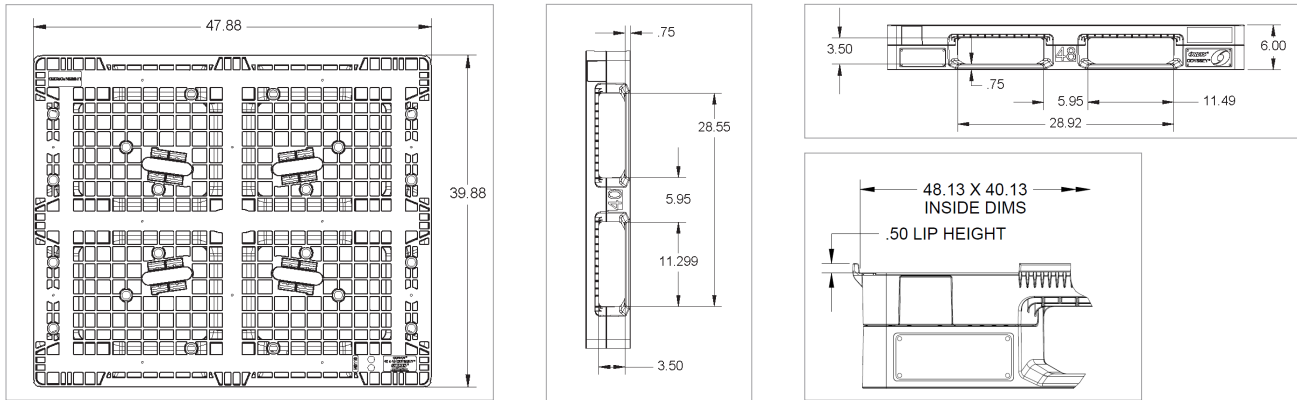

## Frictional Element Configurations

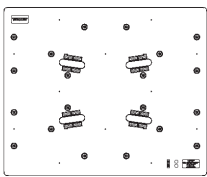

## Optional Features

- ½" discontinuous lip
- Frictional elements
- Molded logos
- Hot stamps
- Track and trace

4048 ODYSSEY HD Pallet Options	Dimensions (in/mm)			Weight (lbs/kg)	Load Capacity (lbs/kg)		Rack Rating (lbs/kg)		40' Truckload Qty	53' Truckload Qty*
	L	W	H		Static	Dynamic	Selective / Edge	Decking / Center		
4048 Odyssey HD Open Deck + Reinforcements**	48.0	40.0	6.0	49.0	30,000	6,000	2,800	6,000	336	540
	1,219	1,016	152	22.2	13,608	2,722	1,270	2,722		
4048 Odyssey HD Solid Deck + Reinforcements**	48.0	40.0	6.0	52.0	30,000	6,000	2,800	6,000	336	540
	1,219	1,016	152	23.6	13,608	2,722	1,270	2,722		

\* Lip models offer a 53' truckload quantity of 510  
 \*\* Reinforcements available 40", 48" or both directions